

# MH6/MH6S/MH6-10 ROBOTS

MH6/MH6-10 robot shown.  
All dimensions are metric (mm) and for reference only. Please request detail drawings for all design/engineering requirements.

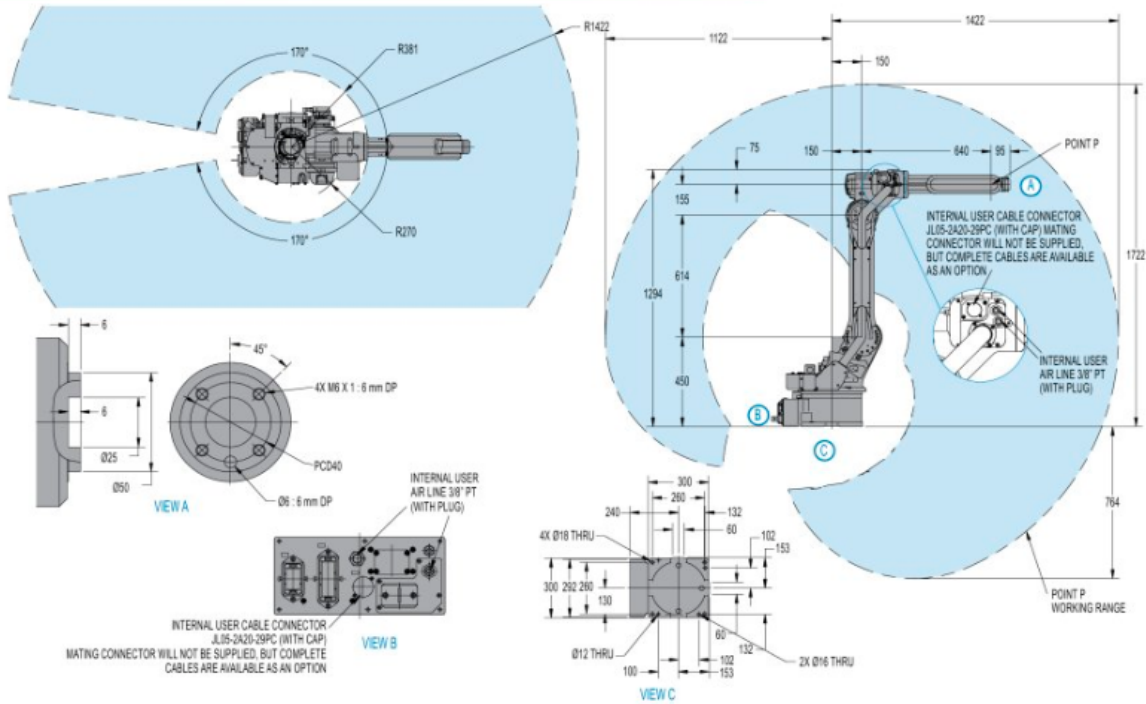

## ROBOT SPECIFICATIONS

	MH6	MH6S	MH6-10
<b>Structure</b>	Articulated	Articulated	Articulated
<b>Controlled Axes</b>	6	6	6
<b>Payload</b>	6 kg (13.2 lbs)	6 kg (13.2 lbs)	10 kg (22.1 lbs)
<b>Vertical Reach</b>	2,486 mm (97.9")	1,597 mm (62.9")	2,486 mm (97.9")
<b>Horizontal Reach</b>	1,422 mm (56")	997 mm (39.3")	1,422 mm (56")
<b>Repeatability</b>	±0.08 mm (±0.003")	±0.08 mm (±0.003")	±0.08 mm (±0.003")
<b>Maximum Motion Range</b>	S-Axis (Turning)	±170°	±170°
	L-Axis (Lower Arm)	+155°/-90°	+133°/-80°
	U-Axis (Upper Arm)	+250°/-175°	+165°/-130°
	R-Axis (Upper Arm Twist)	±180°	±180°
	B-Axis (Pitch/Yaw)	+225°/-45°	+225°/-45°
<b>Maximum Speed</b>	S-Axis	220°/s	140°/s
	L-Axis	200°/s	130°/s
	U-Axis	220°/s	135°/s
<b>Approximate Mass</b>	R-Axis	410°/s	270°/s
	B-Axis	410°/s	270°/s
	T-Axis	610°/s	400°/s
<b>Power Consumption</b>	1.5 kVA	1.5 kVA	1.5 kVA
<b>Allowable Moment</b>	R-Axis	11.8 N·m	12.2 N·m
	B-Axis	9.8 N·m	14.2 N·m
	T-Axis	5.9 N·m	7.3 N·m
<b>Allowable Moment of Inertia</b>	R-Axis	0.27 kg·m²	0.24 kg·m²
	B-Axis	0.27 kg·m²	0.21 kg·m²
	T-Axis	0.06 kg·m²	0.06 kg·m²
<b>Internal User Electrical Cable</b>	16 conductors + ground	16 conductors + ground	16 conductors + ground
<b>Internal User Air Hose</b>	(2) 3/8" PT connections	(1) 3/8" PT connection	(2) 3/8" PT connections

## DX100 CONTROLLER SPECIFICATIONS\*\*

<b>Dimensions (mm)</b>	800 (w) x 1,000 (h) x 650 (d) (31.5" x 39.4" x 25.6")
<b>Approximate Mass</b>	250 kg max. (551.3 lbs)
<b>Cooling System</b>	Indirect cooling
<b>Ambient Temperature</b>	During operation: 0° to 45° C (32° to 113° F) During transit and storage: -10° to 60° C (14° to 140° F)
<b>Relative Humidity</b>	90% max. non-condensing
<b>Primary Power Requirements</b>	3-phase, 240/480/575 VAC at 50/60 Hz
<b>Digital I/O</b>	Standard I/O: 40 inputs/40 outputs consisting of 16 system inputs/16 system outputs, 24 user inputs/24 user outputs NPN-Standard PNP-Optional
<b>Position Feedback</b>	By absolute encoder
<b>Program Memory</b>	JOB: 200,000 steps, 10,000 instructions CIO Ladder Standard: 15,000 steps Expanded: 20,000 steps
<b>Pendant Dim. (mm)</b>	169 (w) x 314.5 (h) x 50 (d) (6.7" x 12.4" x 2")
<b>Pendant Weight</b>	.998 kg (2.2 lbs)
<b>Interface</b>	One Compact Flash slot; One USB port (1.1)
<b>Pendant Playback Buttons</b>	Tech/Play/Remote Keyswitch selector Servo On, Start, Hold, and Emergency Stop Buttons
<b>Programming Language</b>	INFORM III, menu-driven programming
<b>Maintenance Functions</b>	Displays troubleshooting for alarms, predicts reducer wear
<b>Number of Robots/Axes</b>	Up to 8 robots, 72 axes
<b>Multi Tasking</b>	Up to 16 concurrent jobs, 4 system jobs
<b>Fieldbus</b>	DeviceNet Master/Slave, AB RIO, Profibus, Interbus-S, M-Net, CC Link, EtherNet/IP/Slave
<b>Ethernet</b>	10 Base T/100 Base TX
<b>Safety</b>	Dual-channel Emergency Stop Pushbuttons, 3-position Enable Switch, Manual Brake Release Meets ANSI/R15.06-1999, ANSI/R15.06-1999, ANSI/R15.06-1999 and CSA 2434-03

\*\*See DX100 Controller data sheet (DS-399) for complete specifications

www.motoman.com

**YASKAWA**

MOTOMAN ROBOTICS

MOTOMAN ROBOTICS  
100 AUTOMATION WAY, MIAMISBURG, OHIO 45342  
TEL: 937.847.6200 ■ FAX: 937.847.6277

TECHNICAL SPECIFICATIONS SUBJECT TO CHANGE WITHOUT NOTICE  
DS-398-G ©2011 YASKAWA AMERICA, INC. JUNE 2011

MOTOMAN IS A REGISTERED TRADEMARK  
WINDOWS IS A REGISTERED TRADEMARK OF MICROSOFT  
ALL OTHER MARKS ARE THE TRADEMARKS AND  
REGISTERED TRADEMARKS OF YASKAWA AMERICA, INC.